

Technical Specification ACLFUNVETx230

AC LINE FILTER

85 to 264Vrms Input Voltage	5Arms Output Current	500W @ 115Vrms 1kW @ 230Vrms Output Power	180mΩ @ 100°C Max Series Resistance	>55dB @ 250kHz Differential-mode Attenuation (external capacitance required)
--	---------------------------------------	--	--	--

FULL POWER OPERATION: -40°C TO +100°C

The InQor® series of EMI AC Line Filters brings SynQor's field proven technology and manufacturing expertise to the industrial power applications marketplace. SynQor's innovative packaging approach ensures survivability in the most hostile environments. Compatible with the industry standard format, these filters have high differential-mode and common-mode attenuation and low series resistance. They follow conservative component derating guidelines and they are designed and manufactured to the highest standards.

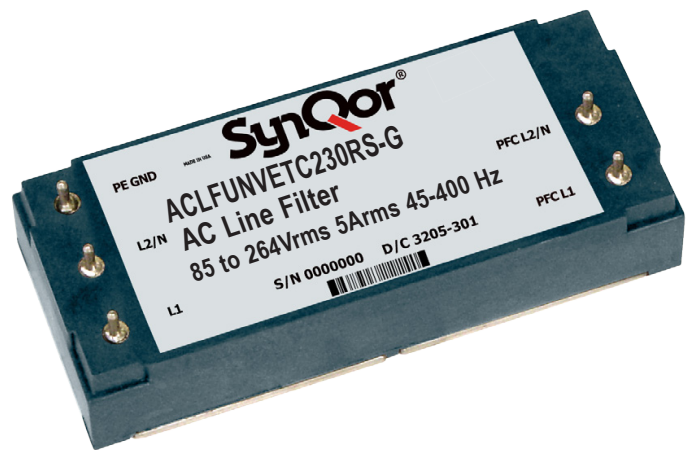

ACLFUNVETC230RS-G Module

Operational Features

- -40°C to +100°C Operation
- 5Arms output current
- Very low series resistance
- High Differential & Common-mode Attenuation
- All capacitors are safety-rated X7R multi-layer ceramic
- Meets common EMC standards in properly designed system with SynQor PFC module and IQ4H converters.

Mechanical Features

- Industry standard half-brick pin-out configuration
- Standard size: 1.00" x 2.39" (25.4 x 60.6)

Safety Features

- 2150Vdc input-to-case and input-to-gnd-pin high-potential test
- Safety rated class X2 line-to-line and class Y2 line-to-gnd capacitors
- Certified 60950-1 requirement for basic insulation (see Standards and Qualifications page)

In-Line Manufacturing Process

- AS9100 and ISO 9001 certified facility
- Full component traceability

CONTENTS

	Page No.
Technical Diagrams	2
Electrical Characteristics	3
Basic Operations and Features	4
Standards & Qualification Testing	5
Encased Mechanical Diagram	6
Flanged Mechanical Diagram	7
Ordering Specifications.	8

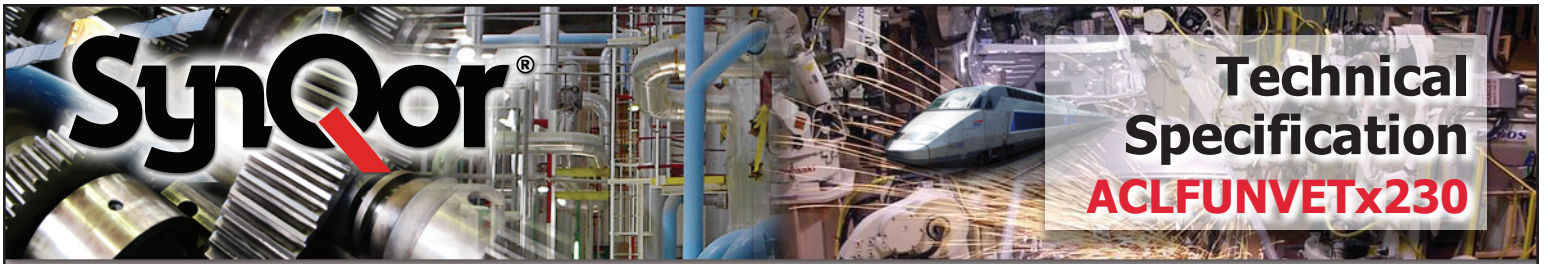

Technical Diagrams

Fundamental Circuit Diagram

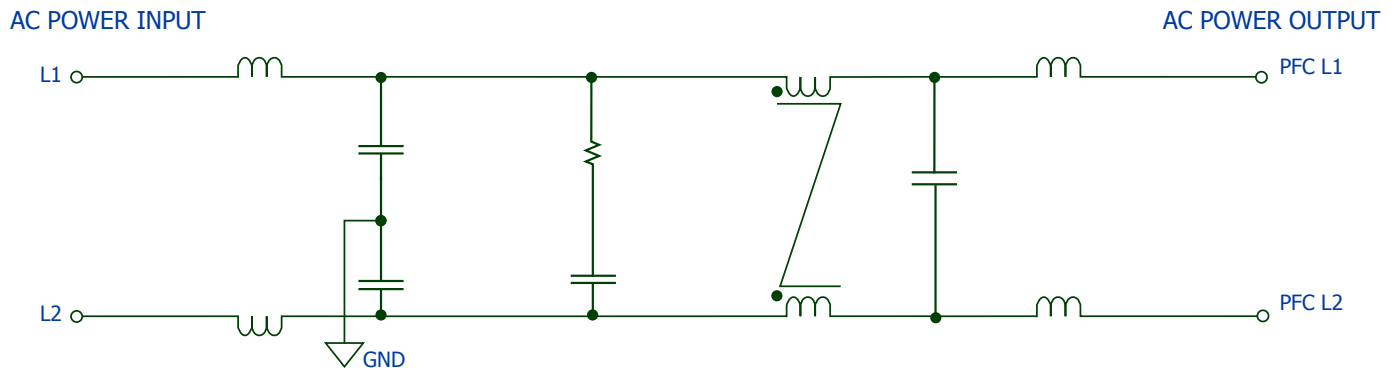

Typical Connection Diagram

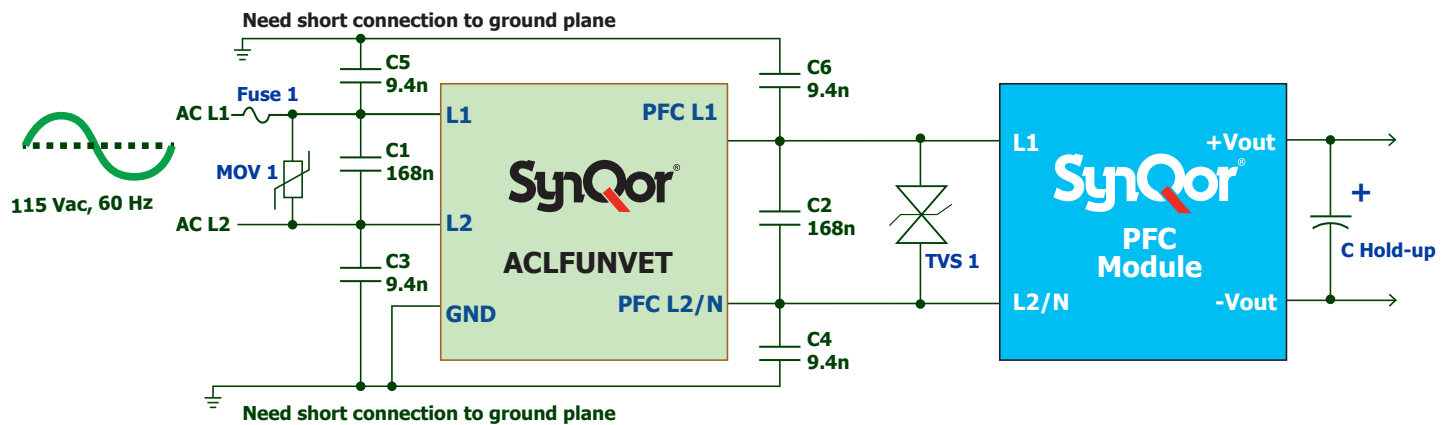

MOV 1: 300VAC, 60J; (EPCOS S10K300E2)

TVS 1: 400V, 3J; (Two VISHAY 1.5KE200CA devices connected in series)

C Hold-up: 450V, 390 μ F; (United Chemi-Con ELXS451VSN391MR50S)

Fuse 1: 250VAC, 6.3A; (Littelfuse 021606.3MXEP)

C1, C2: Three 56nF in parallel; (Murata GA355XR7GB563KW06L)

C3, C4, C5, C6: Two 4.7nF in parallel; (Murata GA355DR7GF472KW01L)

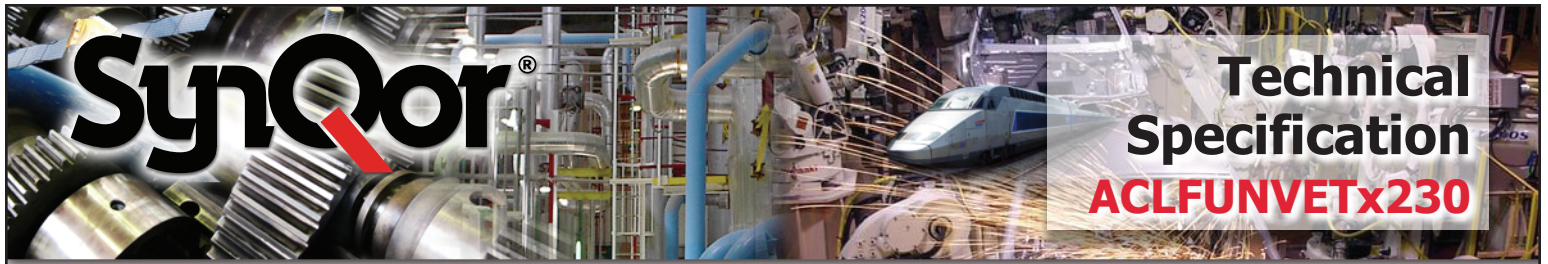

ACLFUNVETx230 Electrical Characteristics

Operating conditions of $V_{in} \leq 264V_{rms}$, $I_{out} \leq 5A_{rms}$ unless otherwise specified, and baseplate temperature = 25°C unless otherwise noted; full operating baseplate temperature range is -40 °C to +100 °C. Specifications subject to change without notice.

Parameter	Min.	Typ.	Max.	Units	Notes & Conditions
ABSOLUTE MAXIMUM RATINGS					
Input Voltage (Continuous)			264	Vrms	
Isolation Voltage			2150	Vdc	Input/output to gnd pin & baseplate
Output Current (Continuous)			5	Arms	
Output Current (Surge)			150	A ² S	
Operating Case Temperature	-40		100	°C	Baseplate temperature
Storage Case Temperature	-45		135	°C	
RECOMMENDED OPERATING CONDITIONS					
Input Voltage (Continuous)			250	Vrms	
Output Current (Continuous)			5	Arms	
Input Frequency	45		800	Hz	Meets EN60950-1 up to 400 Hz, see safety section
ELECTRICAL CHARACTERISTICS					
Output Voltage (Continuous)	$V_{out} = V_{in} - (I_{in} \times R_s)$			V	
Series Resistance R_s					Total
$T_{case} = 25^{\circ}C$		120		mΩ	
$T_{case} = 100^{\circ}C$			180	mΩ	
Power Dissipation					5Arms output current
$T_{case} = 25^{\circ}C$		3.0		W	
$T_{case} = 100^{\circ}C$			4.5	W	
Total Differential-Mode Capacitance		0.5		μF	Measured across input or output pins
Total Common-Mode Capacitance		10		nF	Measured between gnd pin and any other pin
Leakage current in PE GND Pin			0.45	mArms	250Vac L-N 50Hz with no external Y cap, See Note 1
Leakage current in PE GND Pin			3.5	mArms	250Vac L-N 400Hz with no external Y cap, See Note 1
Noise Attenuation					See Fig 1
Isolation Resistance	100			MΩ	Any pin to gnd pins
RELIABILITY CHARACTERISTICS					
Calculated MTBF per Telcordia SR-332, Issue 2		144		10 ⁶ Hrs.	Tb = 70 °C
Calculated MTBF per MIL-HDBK-217F		98		10 ⁶ Hrs.	Tb = 70 °C
Field Demonstrated MTBF				10 ⁶ Hrs.	See our website for details

Note 1: If the neutral line is interrupted, leakage current may reach twice this level.

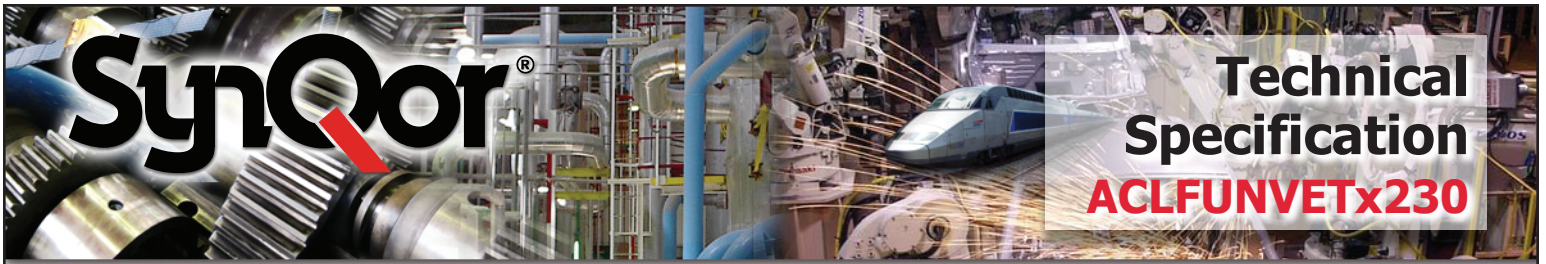

BASIC OPERATION AND FEATURES

This module is a multi-stage differential-mode and common-mode passive EMI filter designed to interface an AC power source with a SynQor PFC module and one or more SynQor converters (or other loads that create EMI). Each stage of this filter is well damped to avoid resonances and oscillations, and only X7R multi-layer ceramic safety rated capacitors are used.

A typical application would place the InQor AC line filter close to the AC input power entry point. The AC Line Filter GND pin would be connected to the chassis ground that is common with AC input power protective earth (PE GND) or other earthed point used for EMI measurement. There are no connections to the metal baseplate, which may also be connected to the chassis ground if desired.

Do not connect the outputs of multiple InQor AC line filters in parallel. Connecting filters in this manner may result in slightly unequal currents to flow in the positive and return paths of each filter. These unequal currents will cause the internal common-mode chokes to saturate and thus cause degraded common-mode rejection performance.

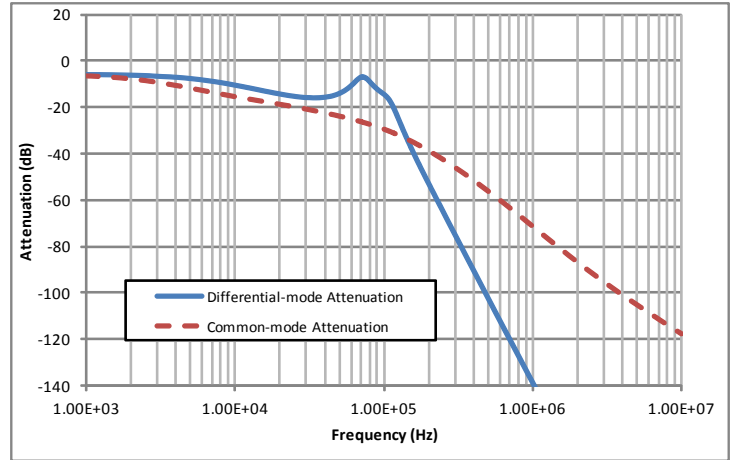
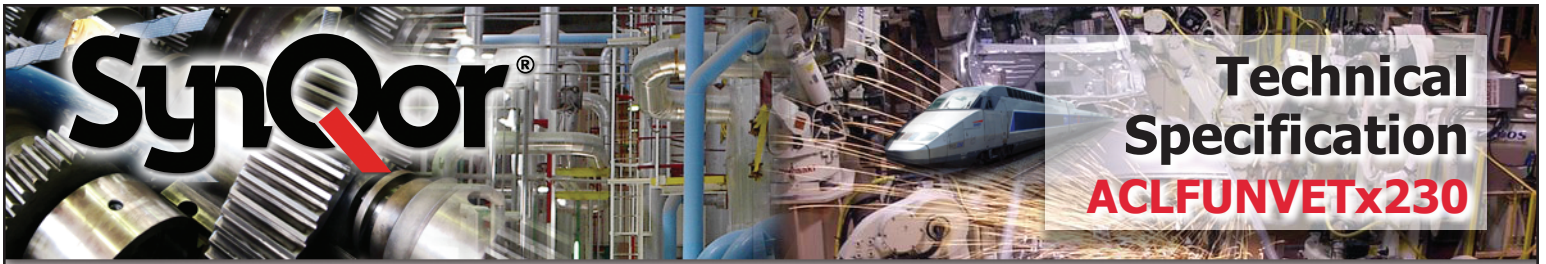

Figure 1: Typical Common Mode and Differential Mode Attenuation provided by the filter as a function of frequency. Source and load resistance are 50Ω.



Technical Specification

ACLFUNVETx230

Standards & Qualification Testing

Parameter	Notes & Conditions
STANDARDS COMPLIANCE	Pending
UL 60950-1	Basic Insulation
CAN/CSA-C22.2 No. 60950-1	
EN60950-1	Certified by TUV

The filter itself meets EN60950-1 leakage current requirements up to 400 Hz input with no externally added common-mode capacitance.

Note: An external input fuse must always be used to meet these safety requirements, see Typical Connection Diagram. Proper protective earthing procedure must be observed for system design. Contact SynQor for official safety certificates on new releases or download from SynQor website.

Parameter	# Units	Test Conditions
QUALIFICATION TESTING		
Life Test	32	95 % rated Vin and load, units at derating point, 1000 hours
Vibration	5	10-55 Hz sweep, 0.060 " total excursion, 1 min./sweep, 120 sweeps for 3 axis
Mechanical Shock	5	100 g minimum, 2 drops in x, y, and z axis
Temperature Cycling	10	-40 °C to 100 °C, unit temp. ramp 15 °C/min., 500 cycles
Power/Thermal Cycling	5	Toperating = min to max, Vin = min to max, full load, 100 cycles
Design Marginality	5	Tmin-10 °C to Tmax+10 °C, 5 °C steps, Vin = min to max, 0-105 % load
Humidity	5	85 °C, 95 % RH, 1000 hours, continuous Vin applied except 5 min/day
Solderability	15 pins	MIL-STD-883, method 2003
Altitude	2	70,000 feet (21 km), see Note

Note: A conductive cooling design is generally needed for high altitude applications because of naturally poor convective cooling at rare atmospheres.

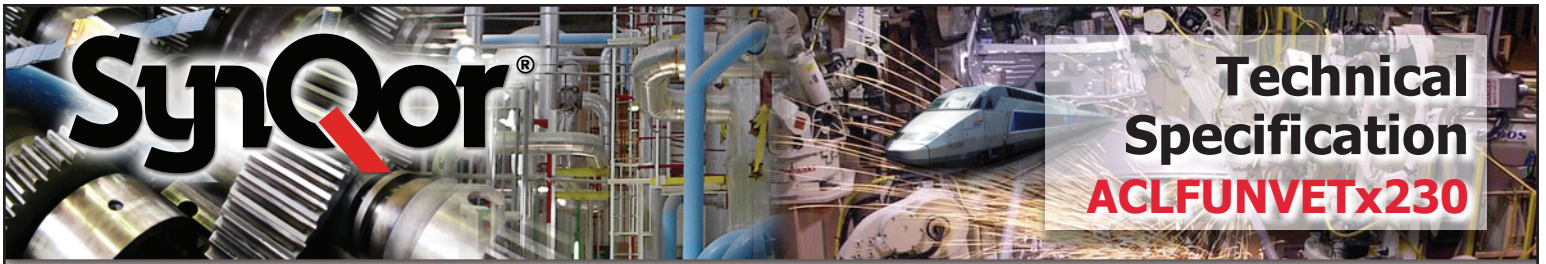

SynQor®

Technical Specification ACLFUNVETx230

Encased Mechanical Diagram

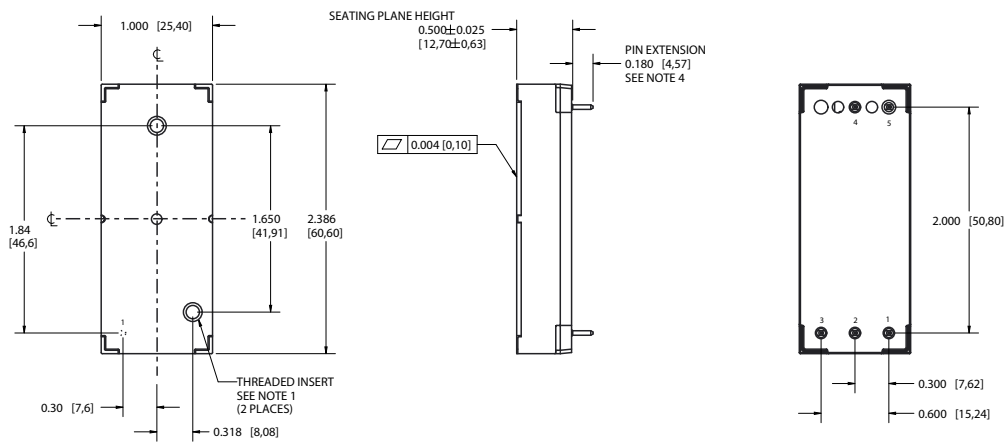

NOTES

- 1) Applied torque per M3 screw is not to exceed 6in-lb (0.7 Nm).
Screw should not exceed 0.100" (2.54mm) below the surface of the baseplate.
- 2) Baseplate flatness tolerance is 0.004" (.10 mm) TIR for surface.
- 3) Pins are 0.040" (1.02mm) diameter, with 0.080" (2.03mm) diameter standoff shoulders.
- 4) All Pins: Material - Copper Alloy
Finish: Matte Tin over Nickel plate
- 5) Undimensioned components only for visual reference.
- 6) Total weight: 2.0oz (56g)
- 7) All dimensions in inches (mm)
Tolerances: x.xx +/-0.02 in. (x.x +/-0.5mm)
x.xxx +/-0.010 in. (x.xx +/-0.25mm)
- unless otherwise noted.
- 8) Workmanship: Meets or exceeds current IPC-A-610 Class II

PIN DESIGNATIONS

Pin	Name	Function
1	L1	AC Line 1
2	L2/N	AC Line 2 / Neutral
3	PE GND	Protective Earth
4	PFC L2/N	PFC Input Line 2 / Neutral
5	PFC L1	PFC Input Line 1

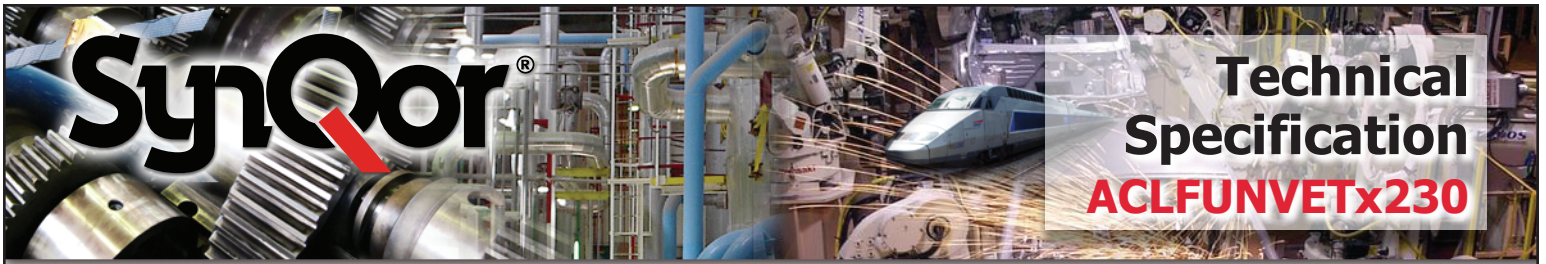

Technical Specification

ACLFUNVETx230

Flanged Mechanical Diagram

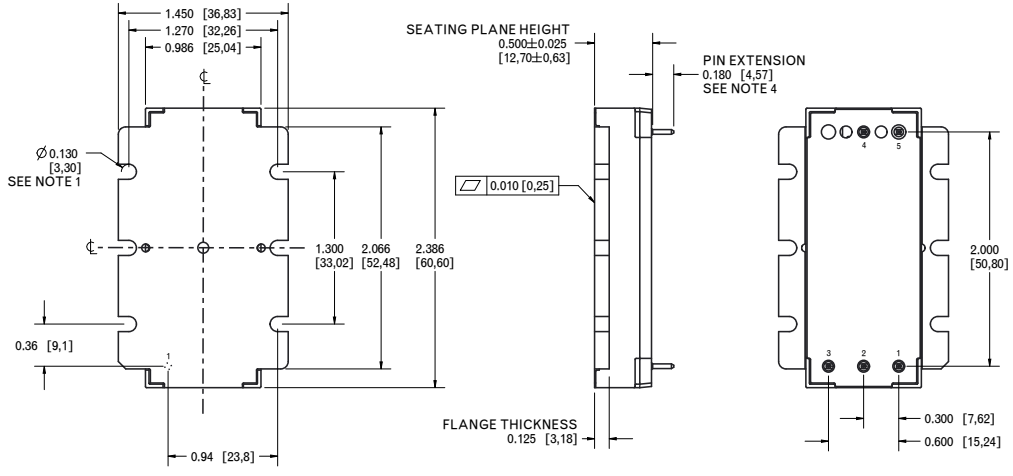

NOTES

- 1) Applied torque per M3 or 4-40 screw is not to exceed 6 in-lb (0.7 Nm)
- 2) Baseplate flatness tolerance is 0.010" (.25 mm) TIR for surface.
- 3) Pins are 0.040" (1.02mm) diameter, with 0.080" (2.03mm) diameter standoff shoulders.
- 4) All Pins: Material - Copper Alloy
Finish: Matte Tin over Nickel plate
- 5) Undimensioned components only for visual reference.
- 6) Weight: 2.2oz (62g)
- 7) All dimensions in inches (mm)
Tolerances: x.xx +/-0.02 in. (x.x +/-0.5mm)
x.xxx +/-0.010 in. (x.xx +/-0.25mm)
- unless otherwise noted.
- 8) Workmanship: Meets or exceeds current IPC-A-610 Class II

PIN DESIGNATIONS

Pin	Name	Function
1	L1	AC Line 1
2	L2/N	AC Line 2 / Neutral
3	PE GND	Protective Earth
4	PFC L2/N	PFC Input Line 2 / Neutral
5	PFC L1	PFC Input Line 1

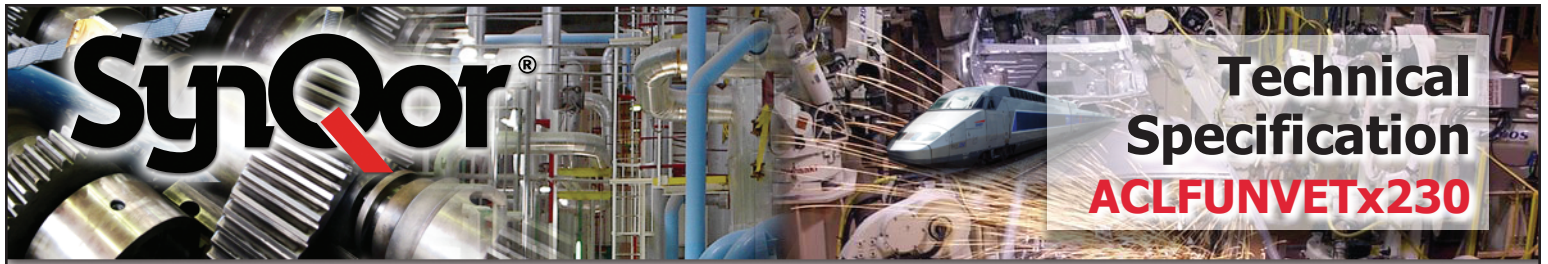

Ordering Specifications

Product Family	Input Frequency	Package	Performance Series	Thermal Design	Input Voltage	Pin Length	Features	-	G
ACLF	UNV	E	T	C	230	R	S	-	G
ACLF :AC Line Filter	UNV :Universal	E :Eighth-brick	T :Tera:	C :Encased V :Flanged	230 :85 to 264Vrms	R :.180"	S :Standard	-	G :RoHs Compliant

APPLICATION NOTES

A variety of application notes and technical white papers can be downloaded in pdf format from our website.

RoHS COMPLIANCE:

The EU led RoHS (Restriction of Hazardous Substances) Directive bans the use of Lead, Cadmium, Hexavalent Chromium, Mercury, Polybrominated Biphenyls (PBB), and Polybrominated Diphenyl Ether (PBDE) in Electrical and Electronic Equipment. This SynQor product is 6/6 RoHS compliant. For more information please refer to SynQor's RoHS addendum available at our [RoHS Compliance / Lead Free Initiative web page](#) or e-mail us at rohs@synqor.com.

ORDERING INFORMATION

The tables below show the valid model numbers and ordering options the filters in this product family. When ordering SynQor filters, please ensure that you use the complete part number including options. A "-G" suffix indicates the product is 6/6 RoHS compliant.

Not all combinations make valid part numbers, please contact SynQor for availability.

Part Number Example: **ACLFUNVETC230RS-G**

Contact SynQor for further information and to order:

Phone: 978-849-0600
Toll Free: 888-567-9596
Fax: 978-849-0602
E-mail: power@synqor.com
Web: www.synqor.com
Address: 155 Swanson Road
 Boxborough, MA 01719
 USA

PATENTS

SynQor holds numerous U.S. patents, one or more of which apply to most of its power conversion products. Any that apply to the product(s) listed in this document are identified by markings on the product(s) or on internal components of the product(s) in accordance with U.S. patent laws. SynQor's patents include the following:

5,999,417	6,222,742	6,545,890	6,594,159	6,894,468	6,896,526
6,927,987	7,050,309	7,072,190	7,085,146	7,119,524	7,269,034
7,272,021	7,272,023	7,558,083	7,564,702	7,765,687	7,787,261
8,023,290	8,149,597	8,493,751	8,644,027	9,143,042	

WARRANTY

SynQor offers a two (2) year limited warranty. Complete warranty information is listed on our website or is available upon request from SynQor.