

### PASSIVE EMI FILTER

<b>-80 to +80V</b> Input	<b>20A</b> Output Current	<b>32mΩ @ 100°C</b> Max DC Resistance	<b>&gt;80dB @ 250kHz</b> Differential Attenuation
-----------------------------	------------------------------	--	--

**FULL POWER OPERATION: -40°C TO +100°C**

The InQor® series of EMI filters brings SynQor’s field proven technology and manufacturing expertise to the industrial power applications marketplace. SynQor’s innovative packaging approach ensures survivability in the most hostile environments. Compatible with the industry standard format, these filters have high differential-mode and common-mode attenuation, low DC resistance, and a stabilizing bulk capacitor resistor. They follow conservative component derating guidelines and they are designed and manufactured to the highest standards.



*IQ080PFQTx20 Module*

#### Operational Features

- -40°C to +100°C Operation
- ±80V Input Voltage Range; ±100V Transient (1s)
- 20A output current
- Very low DC resistance
- >80dB @ 250kHz differential-mode attenuation
- >36dB @ 250kHz common-mode attenuation
- Stabilizing bulk capacitor and damping resistor included
- All capacitors are X7R multi-layer ceramic

#### Mechanical Features

- Standard Size: 1.54" x 2.39" x 0.50" (39.0 x 60.6 x 12.7mm)
- Total weight: 3.53oz (100g)

#### In-Line Manufacturing Process

- AS9100 and ISO 9001 certified facility
- Full component traceability

#### CONTENTS

	Page No.
Technical Diagrams . . . . .	2
Electrical Characteristics . . . . .	3
Basic Operations and Features . . . . .	4
Standards & Qualification Testing . . . . .	5
Encased Mechanical Diagram . . . . .	6
Flanged Mechanical Diagram . . . . .	7
Ordering Specifications. . . . .	8

### Fundamental Circuit Diagram

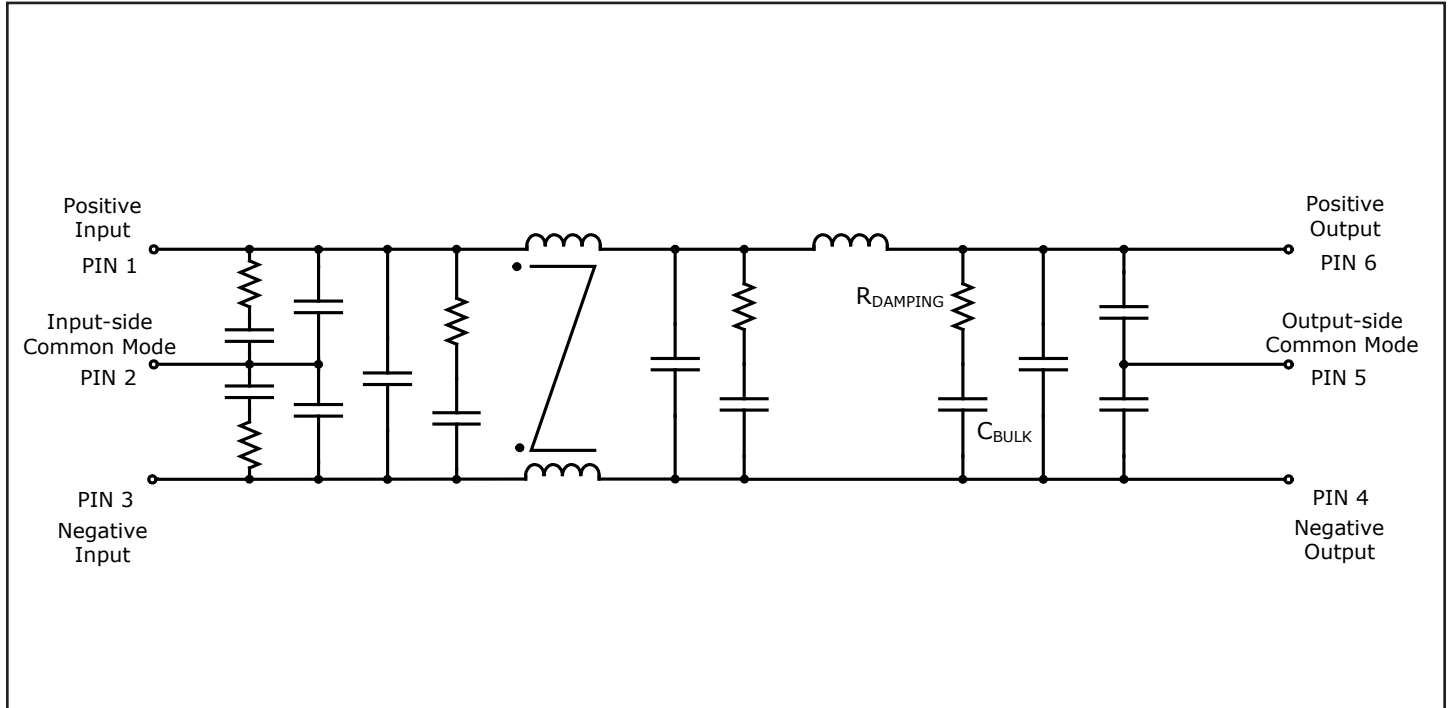

### Typical Connection Diagram

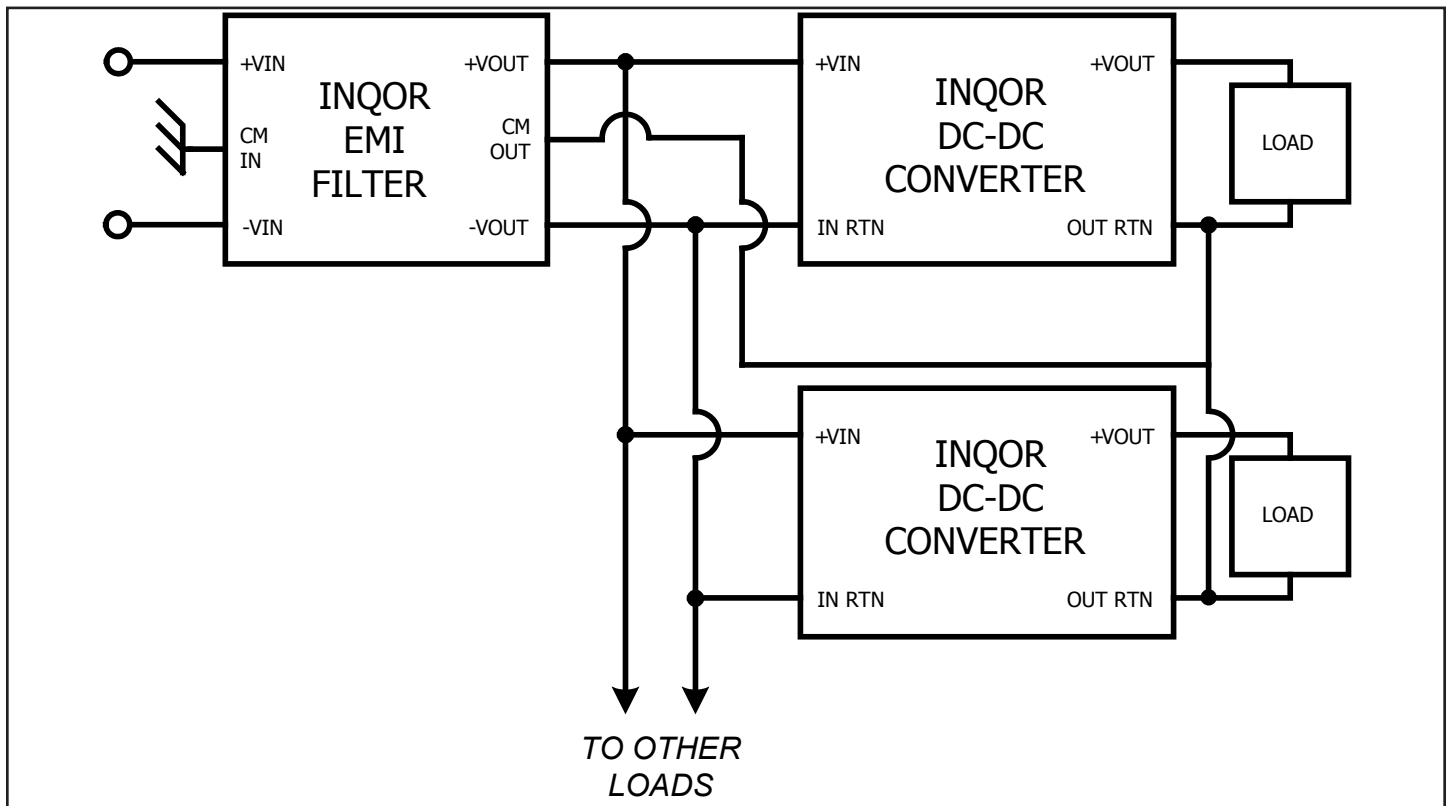

## IQ080PFQTx20 Electrical Characteristics

|Vin| <= ±80V, |Iout| <= 20A unless otherwise specified. Specifications subject to change without notice.

Parameter	Min.	Typ.	Max.	Units	Notes & Conditions
<b>ABSOLUTE MAXIMUM RATINGS</b>					
Input Voltage					
Continuous	-80		+80	V	
Transient (≤ 1 s)	-100		100	V	
Isolation Voltage	-2250		2250	V dc	Input/output to common-mode pins
Output Current			25	A	
Operating Case Temperature	-40		100	°C	Baseplate temperature
Storage Case Temperature	-45		135	°C	
<b>RECOMMENDED OPERATING CONDITIONS</b>					
Input Voltage					
Continuous	-80		+80	V	
Transient (≤ 1 s., Rs* = 0Ω)	-100		100	V	* Rs = Source Impedance
Output Current (continuous)	-20		20	A	
<b>ELECTRICAL CHARACTERISTICS</b>					
Output Voltage (continuous)	Vout = Vin - (Iin x Rdc)			V	
DC Resistance Rdc					Total
Tcase = 25°C			25	mΩ	
Tcase = 100°C			32	mΩ	
Power Dissipation					20A output current
Tcase = 25°C			10	W	
Tcase = 100°C			13	W	
Total Differential-Mode Capacitance		80		μF	Measured across input or output pins
Total Common-Mode Capacitance		0.15		μF	Measured between any pin and common-mode pins
Bulk Capacitor		60		μF	
Damping Resistor		0.2		Ω	
Noise Attenuation					See Figure 1
Isolation Resistance	100			MΩ	Any pin to common-mode pins
<b>RELIABILITY CHARACTERISTICS</b>					
Calculated MTBF (Telcordia) TR-NWT-000332		28.8		10 <sup>6</sup> Hrs.	Tb = 70°C
Calculated MTBF (MIL-217) MIL-HDBK-217F		10.5		10 <sup>6</sup> Hrs.	Tb = 70°C
Field Demonstrated MTBF				10 <sup>6</sup> Hrs.	See our website for details
<b>WEIGHT CHARACTERISTICS</b>					
Device Weight		3.53/100		oz/g	

## BASIC OPERATION AND FEATURES

This module is a multi-stage differential-mode and common-mode passive EMI filter designed to interface a power source with one or more SynQor dc-dc converters (or other loads that create EMI). Each stage of this filter is well damped to avoid resonances and oscillations, and only X7R multi-layer ceramic capacitors are used.

This InQor<sup>®</sup> EMI filter includes a large bulk capacitor with a series damping resistor to correct for the unstabilizing effect of a converter's negative input resistance. A white paper discussing this negative input resistance and the need for corrective damping can be found on the SynQor website (see Input System Instability application note).

A typical application would place the InQor filter close to the input of the dc-dc converter. The Input common-mode pin would be connected to the chassis ground that is common with the system input line filter or other earthed point used for EMI measurement. The output common-mode pin would be connected to the output ground or plane of the power converters with as low inductance a path as possible. There are no connections to the metal baseplate, which may also be connected to the chassis ground if desired.

Do not connect the outputs of multiple InQor filters in parallel. Connecting filters in this manner may result in slightly unequal currents to flow in the positive and return paths of each filter. These unequal currents may cause the internal common-mode chokes to saturate and thus cause degraded common-mode rejection performance.

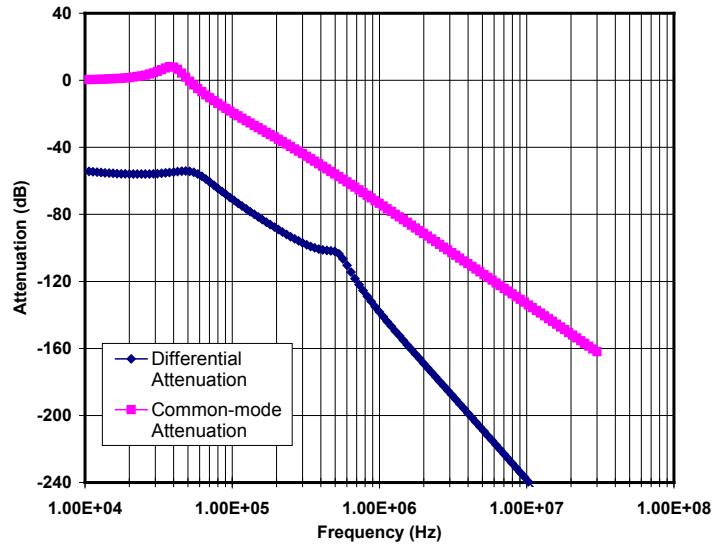

**Figure 1:** Calculated Common Mode and Differential Mode Attenuation provided by the filter as a function of frequency. both input lines are connected to chassis ground through 50Ω resistors.

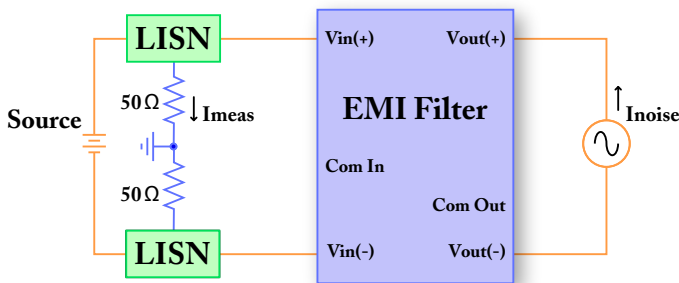

**Figure 2:** Differential-Mode Current Attenuation,  $I_{meas} / I_{noise}$

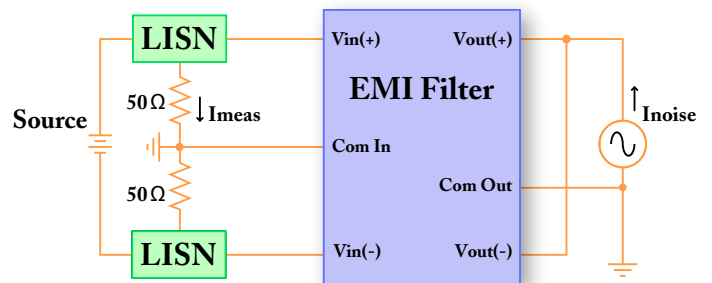

**Figure 3:** Common-Mode Current Attenuation,  $I_{meas} / I_{noise}$



Parameter	Notes & Conditions
<b>STANDARDS COMPLIANCE</b>	
UL 60950-1	Basic Insulation
CAN/CSA C22.2 No. 60950-1	
EN 60950-1	

Note: An external input fuse must always be used to meet these safety requirements. Contact SynQor for official safety certificates on new releases or download from the SynQor website.

Parameter	# Units	Test Conditions
<b>QUALIFICATION TESTING</b>		
Life Test	32	95 % rated Vin and load, units at derating point, 1000 hours
Vibration	5	10-55 Hz sweep, 0.060 " total excursion, 1 min./sweep, 120 sweeps for 3 axis
Mechanical Shock	5	100 g minimum, 2 drops in x, y, and z axis
Temperature Cycling	10	-40 °C to 100 °C, unit temp. ramp 15 °C/min., 500 cycles
Power/Thermal Cycling	5	Toperating = min to max, Vin = min to max, full load, 100 cycles
Design Marginality	5	Tmin-10 °C to Tmax+10 °C, 5 °C steps, Vin = min to max, 0-105 % load
Humidity	5	85 °C, 95 % RH, 1000 hours, continuous Vin applied except 5 min/day
Solderability	15 pins	MIL-STD-883, method 2003
Altitude	2	70,000 feet (21 km), see Note

Note: A conductive cooling design is generally needed for high altitude applications because of naturally poor convective cooling at rare atmospheres.

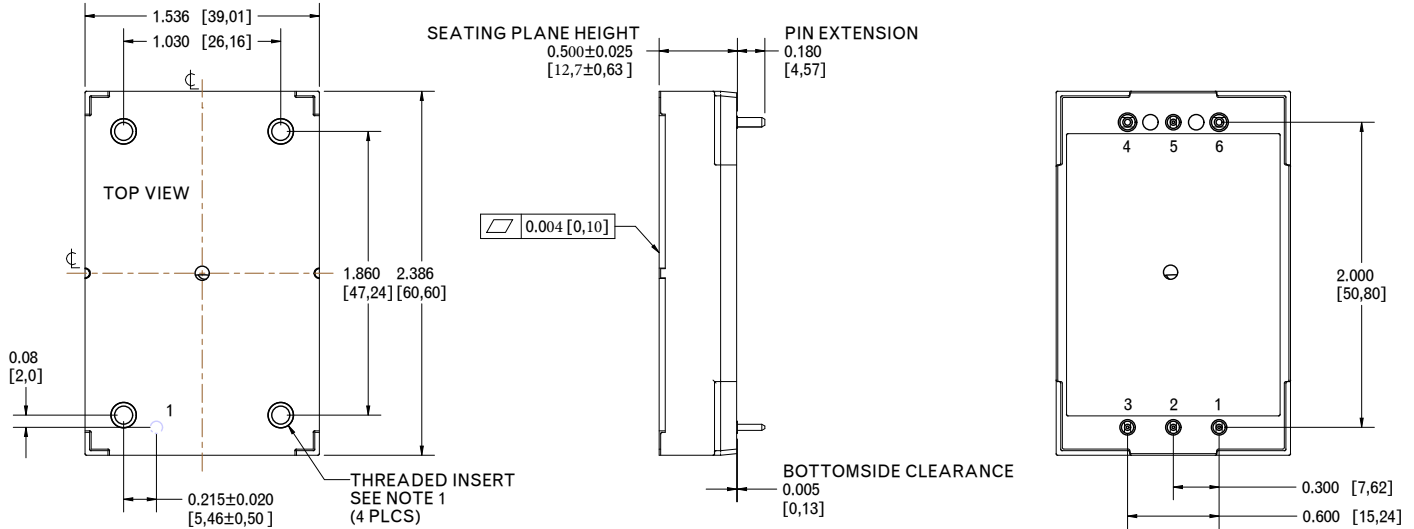

### NOTES

- Applied torque per M3 screw should not exceed 6in-lb (0.7Nm). Screw should not exceed 0.100" (2.54mm) depth below the surface of the baseplate.
- Baseplate flatness tolerance is 0.004" (.10 mm) TIR for surface.
- Pins 1-3 & 5 are 0.040" (1.02mm) diameter, with 0.080" (2.03mm) diameter standoff shoulders.
- Pins 4 & 6 are 0.062" (1.57 mm) diameter with 0.100" (2.54mm) diameter standoff shoulders.
- All Pins: Material - Copper Alloy  
Finish: Matte Tin over Nickel plate
- Total weight: 3.53oz (100g)
- All dimensions in inches (mm)  
Tolerances: x.xxIN +/-0.02 in. (x.xmm +/-0.5mm)  
x.xxxIN +/-0.010 in. (x.xxmm +/-0.25mm)

### PIN DESIGNATIONS

Pin	Name	Function
1	Vin(+)	Positive input voltage
2	Com In	Input-side common-mode
3	Vin(-)	Negative input voltage
4	Vout(-)	Negative output voltage
5	Com Out	Output-side common-mode
6	Vout(+)	Positive output voltage

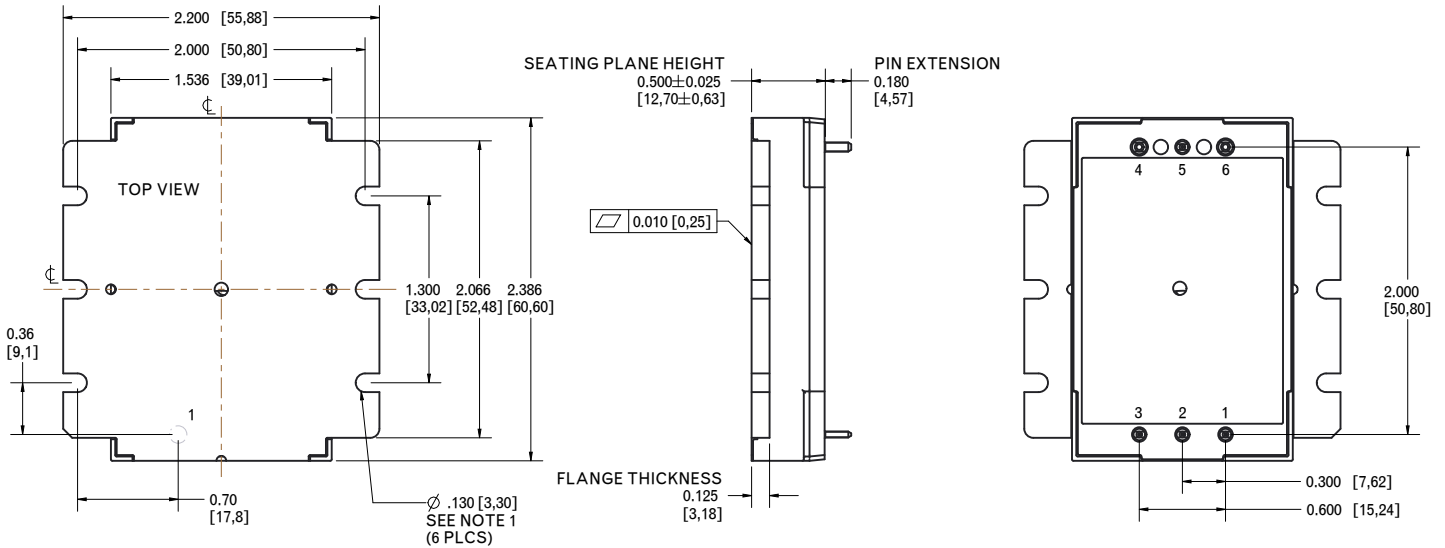

### NOTES

- Applied torque should not exceed 6in-lb (0.7Nm)
- Baseplate flatness tolerance is 0.004" (.10mm) TIR for surface.
- Pins 1-3 & 5 are 0.040" (1.02mm) Dia. with 0.080" (2.03mm) Standoff shoulders
- Pins 4 & 6 are 0.062" (1.57mm) Dia. with 0.100" (2.54mm) Dia. Standoff shoulders
- All Pins: Material - Copper Alloy  
Finish: Matte Tin over Nickel plate
- Weight: 3.74oz. (106g) typical
- All dimensions in inches (mm)  
Tolerances: x.xx +/-0.02 in. (x.x +/-0.5mm)  
x.xxx +/-0.010 in. (x.xx +/-0.25mm)

### PIN DESIGNATIONS

Pin	Name	Function
1	Vin(+)	Positive input voltage
2	Com In	Input-side common-mode
3	Vin(-)	Negative input voltage
4	Vout(-)	Negative output voltage
5	Com Out	Output-side common-mode
6	Vout(+)	Positive output voltage



# Ordering Specifications

# Technical Specification IQ080PFQTx20

## Application Notes

A variety of application notes and technical white papers can be downloaded in pdf format from our website.

**RoHS Compliance:** The EU led RoHS (Restriction of Hazardous Substances) Directive bans the use of Lead, Cadmium, Hexavalent Chromium, Mercury, Polybrominated Biphenyls (PBB), and Polybrominated Diphenyl Ether (PBDE) in Electrical and Electronic Equipment. This SynQor product is 6/6 RoHS compliant. For more information please refer to SynQor's RoHS addendum available at our [RoHS Compliance / Lead Free Initiative web page](#) or e-mail us at [rohs@synqor.com](mailto:rohs@synqor.com).

## ORDERING INFORMATION

The tables below show the valid model numbers and ordering options the filters in this product family. When ordering SynQor filters, please ensure that you use the complete 15 character part number consisting of the 12 character base part number and the additional 3 characters for options. A "-G" suffix indicates the product is 6/6 RoHS compliant.

Model Number	Continuous Input Voltage	Max Output Current
<b>IQ080PFQTw20SRS-G</b>	<b>-80 to +80V</b>	<b>20A</b>

The following options must be included in place of the **wxyz** spaces in the model numbers listed above.

Thermal Design <b>w</b>	Enable Logic <b>x</b>	Pin Style <b>y</b>	Feature Set <b>z</b>
C - Encased V - Encased with Flange	S - Standard	R - 0.180"	S - Standard

Not all combinations make valid part numbers, please contact SynQor for availability. See the [Product Summary web page](#) for more options.

## Contact SynQor for further information and to order:

**Phone:** 978-849-0600  
**Toll Free:** 888-567-9596  
**Fax:** 978-849-0602  
**E-mail:** [power@synqor.com](mailto:power@synqor.com)  
**Web:** [www.synqor.com](http://www.synqor.com)  
**Address:** 155 Swanson Road  
 Boxborough, MA 01719  
 USA

## PATENTS

SynQor holds numerous U.S. patents, one or more of which apply to most of its power conversion products. Any that apply to the product(s) listed in this document are identified by markings on the product(s) or on internal components of the product(s) in accordance with U.S. patent laws. SynQor's patents include the following:

5,999,417	6,222,742	6,545,890	6,594,159	6,894,468	6,896,526
6,927,987	7,050,309	7,072,190	7,085,146	7,119,524	7,269,034
7,272,021	7,272,023	7,558,083	7,564,702	7,765,687	7,787,261
8,023,290	8,149,597	8,493,751	8,644,027	9,143,042	

## WARRANTY

SynQor offers a two (2) year limited warranty. Complete warranty information is listed on our website or is available upon request from SynQor.